

# B BETA FENCE

PO Box 119  
Shepcote Lane  
Sheffield S9 1TY  
T: 0870 1270027  
F: 0870 1270028  
Email: sales.sheffield@betafence.com

## Product Description

**2.70/3.20mm PVC coated Gabion**

**Mattress**

Spec. No. 270320Matt Issue 3

01.05.05

### Format:

Betafence Weldmesh mattresses are manufactured from hard drawn mild steel wires formed into a bi-axial mesh grid and joined by electrically welding the cross wires at every intersection.

**Betafence mattresses:** are supplied "flat packed" with factory fitted stainless steel clips to all adjacent panels, and plastic cable ties for temporary connections.

Mattresses are supplied with internal diaphragm panels positioned to form compartments no larger than 1m x 1m. The mattress should be installed such that the diaphragms minimise the migration of stone within the unit.

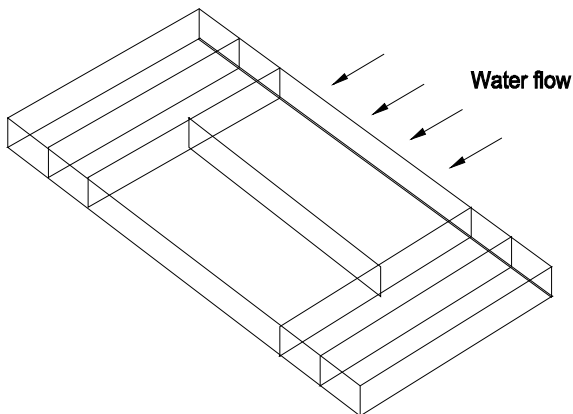

Diaphragm to prevent movement of the fill by the action of the water, at 0.5m or 1m centres dependant upon water flow rate.



Diaphragms at 1m centres to prevent downward shift of rock fill

**Specification:**

Mesh Aperture	Wire Diameter	Corrosion Protection	PVC	Stainless Steel	Durability
76.2mm (3")	2.70mm ID  3.20mm OD	Galvanised 240g /m <sup>2</sup> min. with a bonded PVC coating of nominal 0.25mm thickness	Colour  Grey : RAL 7037 Green: RAL 6005	2.00mm Type 304 S31	120 years in a mild environment
References	BS1052	BS En 10244 -2		BS1554	BBA certificate no.s 00/3683

**Rock-fill:** Gabion fill shall be a hard durable and non-frost susceptible (rock or stone type), block size of 75mm – 150mm.

**Construction:** All rock-fill shall be packed tightly to minimise voids and the rock-fill on the exposed face of the gabion is to be hand-packed.

**Assembly:** After filling of the mattress, the lid panel should be firmly secured along all outer edges and diaphragms, by either continuous lacing with PVC coated lacing wire or clipped using stainless steel hog rings. Hog rings should be placed at every other mesh aperture.

**Modification:** To install mattresses on curves or over embankments, the preferred method of modification is to cut or overlap necessary panels and reconnect using either lacing wire or clips as previously described. For curves, the base and lid panels of the mattress are cut or overlapped, any diaphragm panels are cut down to length. For mattresses laid over embankments, the side and diaphragm panels are cut and overlapped. Lid and base panels are bent to achieve the curve.

